

Design and experiment of Internet- of -Things cooling system in glass greenhouse based on computational fluid dynamics simulation

Zanbin Zhu,^{1,2} Yubin Li,^{1,3} Shoufu Gong¹

¹College of Horticulture, Xinyang Agriculture and Forestry University; ²College of Mechanical and Electrical Engineering, Northeast Forestry University, Haerbin; ³College of Horticulture, Hainan University, Haikou, China

Abstract

In the summer heat season, the performance of the greenhouse cooling system is the key factor in greenhouse crop pollination and fruit formation. Scientific design of greenhouse cooling systems and intelligent control of cooling equipment can ensure the normal growth of greenhouse crops and save energy. In this paper, the thermal equilibrium theory of the greenhouse is analysed, and the glass greenhouse thermal environment model is established based on the theory of engineering thermophysics combined with greenhouse environmental regulation. This study uses computational fluid dynamics simulation technology to simulate the

change of the greenhouse temperature field, perform experimental analysis, and scientifically design an intelligent greenhouse temperature control cooling system. It provides a reference for designing an internet of things cooling system in a glass greenhouse in theoretical analysis and engineering practice.

Introduction

In recent years, research about greenhouse cooling systems has become a hot spot with the rapid development of facility agriculture. Computational fluid dynamics (CFD) simulation techniques are widely used in the research of greenhouse cooling systems due to their ability to simulate the changing characteristics of fluids accurately and clearly show the climate environment inside the greenhouse. Xu *et al.* (2015) used CFD to simulate the distribution of the temperature field and velocity field in different planes of Venlo-type greenhouse in the east China coastal area in summer and proposed a cooling environment optimisation design method for greenhouse wet curtain-fan system based on CFD. According to the results of different configuration schemes obtained by simulation optimisation, the fitting results of greenhouse length, wet curtain area, and fan speed parameters were established, which provided a reliable theoretical basis for the design of Venlo-type greenhouse wet curtain-fan cooling system in coastal East China area in summer (Xu *et al.*, 2015). Shougang *et al.* (2015) established a greenhouse temperature spatio-temporal change prediction model. According to the model prediction results and greenhouse control objectives, selecting appropriate time points, time lengths, and different types of ventilation cooling measures can effectively improve the efficiency and effect of greenhouse temperature control (Shougang *et al.*, 2015). Ghoulem *et al.* (2019) introduced the working principle, working conditions, and performance parameters of greenhouse cooling technology from theoretical and practical aspects. Studies have shown that the combination and simultaneous use of natural ventilation, evaporative cooling, and shading can reduce greenhouse energy requirements and optimise indoor conditions (Ghoulem *et al.*, 2019). Weituo *et al.* (2019) studied and constructed the calculation model of solar greenhouse cooling load and the reasonable selection method of wet curtain cold air-cooling equipment. The cooling load model is the basis for selecting cooling equipment, which is generally applicable to the research of various solar greenhouse cooling methods (Weituo *et al.*, 2019). Boulard *et al.* (2017) established a CFD model to predict temperature, water vapor, and CO₂ distribution in an air-conditioned Venlo-type semi-enclosed glass greenhouse. The simulation results show that the higher the LAD value of the high canopy, the stronger the cooling intensity of the indoor air. They also enhanced temperature stratification, resulting in a significant drop in canopy levels (Boulard *et al.*, 2017). Ghoulem *et al.* (2020) used CFD to study the cooling effect of a passive wind catcher and evaporative cool-

Correspondence: Zanbin Zhu, College of Horticulture, Xinyang Agriculture and Forestry University, Xinyang, Henan, 464000, China.

E-mail: zlx20063500@126.com

Key words: CFD, cooling system, glass greenhouse, thermal environment.

Contributions: the authors contributed equally.

Conflict of interest: the authors declare no potential conflict of interest.

Funding: New Agricultural Science Research and Reform Project of Henan Province in 2020, No. 2020JGLX147; Science and Technology Innovation Team Project of Xinyang Agriculture and Forestry College, No. XNKJTD-011; Research Fund for Young Teachers of Xinyang Agriculture and Forestry College, No. 20200110.

Availability of data and materials: data and materials are available from the corresponding author upon request.

Received: 17 February 2022.

Accepted: 12 July 2022.

Early view: 25 July 2022.

©Copyright: the Author(s), 2023

Licensee PAGEPress, Italy

Journal of Agricultural Engineering 2023; LIV:1384

doi:10.4081/jae.2023.1384

This work is licensed under a Creative Commons Attribution-NonCommercial 4.0 International License (CC BY-NC 4.0).

Publisher's note: all claims expressed in this article are solely those of the authors and do not necessarily represent those of their affiliated organizations, or those of the publisher, the editors and the reviewers. Any product that may be evaluated in this article or claim that may be made by its manufacturer is not guaranteed or endorsed by the publisher.

ing system in the greenhouse. The results show that the system can reduce the average indoor air temperature by 17.13°C, and the trapping effect is reduced when there are other structures around the greenhouse (Ghoulem *et al.*, 2020). Santolini *et al.* (2022) studied the effect of shading screens on airflow patterns within the greenhouse through CFD simulations. Alternative models based on an artificial neural network are also reported for greenhouse system analysis to relieve the computational burden of CFD simulation. For these data-driven models, the modelling error issue could not be ignored (Liu *et al.*, 2019). In this paper, the greenhouse thermal environment model is established, the distribution of the internal temperature of the greenhouse is analysed by combining CFD simulation technology, and the greenhouse cooling system is optimised. The research results mainly apply to the glass greenhouse cooling system research.

Materials and Methods

Analysis of greenhouse cooling systems

Composition of greenhouse cooling system

The internet of things (IoT) cooling system is a wet curtain-fan cooling system as the main cooling equipment, all controlled by an intelligent control system. It can be connected to a mobile phone. Through the mobile phone, users can observe the changes in temperature and humidity in the greenhouse and adjust the startup and shutdown of the cooling system anytime and anywhere to realise remote control (Jia *et al.*, 2019; Hu, 2020; Wu *et al.*, 2021).

The wet curtain-fan cooling system generally consists of a wet curtain made of corrugated fibres, an axial flow fan, a water circulation system, and a control device (Liu *et al.*, 2018; Li *et al.*, 2019). The system adopts negative pressure ventilation to lower the temperature. The fan and the wet curtain are installed on the two opposite walls of the greenhouse, respectively. When the fan is working, the air in the greenhouse is pumped out to form a negative pressure area so that the external air enters from the wet curtain and flows through the porous wet curtain surface. Then the water evaporates and absorbs heat so the greenhouse air temperature is reduced. As a result, it has a good cooling effect, moderate price, convenient operation, and a wide application range (Dong, 2019; Ma, 2020).

The shading cooling system uses opaque or low light transmittance materials to block sunlight, prevent part of the solar radiation energy from the greenhouse, reduce the temperature in the greenhouse, and ensure the normal growth of crops. It is low cost and stable cooling. At present, the combined cooling efficiency of the wet curtain-fan cooling system and the shading cooling system is the best (Zhao *et al.*, 2011; Xu, 2017; Zhou *et al.*, 2018).

The theoretical basis of the cooling system in a glass greenhouse

The greenhouse is a semi-closed system that constantly exchanges energy and materials with the outside world. The greenhouse heat mainly derived from solar radiation heat Q_r and heat transfer of enclosure structure Q_t . The heat destination in the greenhouse mainly includes the heat consumed by artificial cooling, that is, the quantity of cold air produced by artificial cooling Q_g , the quantity of cold air loss Q_v and the conduction in the soil ground in the greenhouse Q_s . The heat stored and accumulated in the greenhouse mainly affects the quantity of latent heat exchange

Q_L of crops, the heat exchange Q_c of solid materials, the heat exchange Q_a of air, and the energy exchange Q_p of crops used for photosynthesis and respiration in the environment (Boulard *et al.*, 2010; Cheng *et al.*, 2011; Franco *et al.*, 2011). Therefore, the balance of heat income and expenditure can be expressed as follows:

$$Q_g - Q_v + Q_s + Q_L + Q_c + Q_a + Q_p = Q_r + Q_t \quad (1)$$

The greenhouse cooling theory is calculated in terms of cold load, which is the heat consumed or discharged when the temperature in the greenhouse reaches the required for the normal growth of crops (indoor design temperature) (Bournet and Boulard, 2010).

The purpose of designing greenhouse cooling is to reduce the temperature in the glass greenhouse by increasing the quantity of cooling produced by artificial cooling Q_g to provide a suitable temperature to ensure the normal growth and development of the crops.

In Eq. 1, Q_s , Q_c , Q_a , and Q_p are positive if they absorb the heat of the greenhouse and reduce the temperature of the greenhouse; otherwise, they are negative. Energy exchange, such as the conduction in the soil ground Q_s , the heat exchange Q_c of solid materials, the heat exchange Q_a of air, and the energy exchange Q_p of crops used for photosynthesis and respiration in the environment have little influence on the change of greenhouse heat, which can be neglected. That is, the calculation formula of the total cooling load required for greenhouse cooling can be simplified as follows:

$$Q_g = Q_r + Q_t + Q_v - Q_L \quad (2)$$

In Eq. 1 and 2: Q_r is the solar radiation heat, J ; Q_t is the heat transfer of enclosure structure, J ; Q_g is the quantity of cold air produced by artificial cooling, J ; Q_v is the quantity of cold air loss, J ; Q_s is the conduction in the soil ground, J ; Q_L is the quantity of latent heat exchange of crops, J ; Q_c is the heat exchange of solid materials, J ; Q_a is the heat exchange of air, J ; Q_p is the energy exchange of crops used for photosynthesis and respiration in the environment, J .

Design of greenhouse cooling system

The experimental greenhouse is a Venlo-type glass greenhouse with a roof along the north-south direction, lengths of 40 m, a total of 6 spans, a single span of 3.2 m, and a total area of 768 m²; Eave height of 3.8 m, ridge height of 5 m. This greenhouse body is made of a lightweight steel structure; the greenhouse is maintained with 5 mm float glass around the perimeter, and the roof covering material is a 6 mm PC polycarbonate hollow sheet.

Calculation of the total cooling load required for cooling

The core of the greenhouse automatic cooling system is a wet curtain-fan cooling system. In this experiment, the calculated outdoor dry bulb temperature of air conditioning in summer was 34.5°C, and the calculated indoor wet bulb temperature of air conditioning in summer was 27.7°C. Therefore, calculations are based on an outdoor temperature of 34.5°C, an indoor design temperature of 28°C, and a horizontal solar irradiance of 1030 W/m² in summer. The total cooling load required for greenhouse cooling in summer is calculated by formula (2) in which solar radiation heat is calculated as follows:

$$Q_r = (1 - \lambda) \tau_0 E A_s \quad (3)$$

where λ is the shading reduction rate, $\lambda = 0.35$; τ_0 is the solar radiation transmittance of the greenhouse covering layer, top 6 mm PC solar panels, $\tau_0 = 0.79$; E is the outdoor solar irradiance, W/m²; A_s is

the total greenhouse area, m^2 . The heat transmitted from outdoors to indoors by the enclosure structure of the greenhouse is calculated according to Eq. 4:

$$Q_t = \sum_{i=1}^n K_i A_i (t_1 - t_2) a_1 a_2 \quad (4)$$

In Eq. (4): K_i is the heat transfer coefficient of the greenhouse enclosure structure, refer to the data to know the heat transfer coefficient of 5 mm float glass $K_1=6.7 \text{ W}/(\text{m}^2 \cdot \text{K})$ 6 mm PC polycarbonate hollow sheet heat transfer coefficient $K_2 = 3.5 \text{ W}/(\text{m}^2 \cdot \text{K})$; A_i is the heat transfer area of greenhouse the enclosure structure, m^2 ; t_1 is the outdoor temperature, $^\circ\text{C}$; t_2 is the indoor design temperature, $^\circ\text{C}$; a_1 is the additional correction coefficient of the greenhouse structure form, metal structure glass greenhouse, frame spacing 1.2 m, $a_1=1.05$; a_2 is the additional correction factor for wind power, below grade 4 ($<6.71 \text{ m/s}$), $a_2=1.0$.

The quantity of cold air loss is calculated according to Eq. (5):

$$Q_v = \gamma C_p F V (t_1 - t_2) \quad (5)$$

In Eq. (5): C_p is the constant pressure heat capacity of air quality, for greenhouse ventilation engineering common situation is $C_p=1.006 \text{ kJ}/(\text{kg} \cdot ^\circ\text{C})$; F is the air exchange rate between the greenhouse and the outside world, also known as the number of air changes, per hour to complete the number of air exchange as a unit, a single-layer glass, glass lap gap-sealed new greenhouse can select, $F=1$; V is the internal volume of the greenhouse, $V=3.3792 \times 10^3 \text{ m}^3$; γ is the bulk density of air at outdoor temperature conditions, $\gamma=1.164 \text{ kg}/\text{m}^3$.

The quantity of latent heat exchange of crops is calculated according to Eq. (6):

$$Q_L = \beta(1-\lambda)\tau_0 E A_s \quad (6)$$

In Eq. (6), β is the heat loss coefficient of transpiration and evaporation can select $\beta=0.7$.

The total cooling load required for greenhouse cooling in this test, calculated by Eq. (2) to (6):

$$Q_g = 173563.554112 \text{ W} \approx 173.564 \text{ kW}$$

Ventilation volume calculation

In this design, the wet curtain-fan cooling system is used to cool the air, and the ventilation volume of the wet curtain-fan system, calculated according to Eq. (7):

$$M_e = \frac{Q_g}{\rho C_p (t_4 - t_3)} \quad (7)$$

In Eq. (7): M_e is the ventilation volume of the wet curtain-fan cooling system, m^3/s ; ρ is the air density at the air outlet, $\rho=1.2 \text{ kg}/\text{m}^3$; t_3 is the dry bulb temperature before the air passes through the wet curtain, $^\circ\text{C}$; t_4 is the dry bulb temperature after the air passes through the wet curtain, $^\circ\text{C}$.

Among them, the dry bulb temperature after the air passes through the wet curtain is calculated according to Eq. (8):

$$t_4 = (1-\eta)t_3 + \eta t_{s1} \quad (8)$$

In Eq. (8): η is the heat exchange efficiency of wet curtain,

$\eta=80\%$; t_{s1} is the outdoor air wet bulb temperature, $^\circ\text{C}$.

According to Eq. (6) and Eq. (7), $M_e \approx 26.43 \text{ m}^3/\text{s}$

The design scheme of the cooling system

The design of the wet curtain-fan cooling system meets the greenhouse ventilation volume and considers the greenhouse basic structure, so the wet curtain's design area is 26.25 m^2 ($17.5 \times 1.5 \text{ m}$). The water absorption rate of the wet curtain is about 98%, the humidification efficiency is about 85%, the strength is high, and it is durable. The greenhouse is equipped with four axial flow fans (380 V, 1.1 KW) with a diameter of 1.38 m, and the air volume is $44,500 \text{ m}^3/\text{h}$. The wet curtain was installed on the south wall of the greenhouse, 0.65 m above the ground, and the fan was installed on the north wall of the greenhouse, 0.5 m above the ground. The design of the greenhouse cooling system is shown in Figure 1.

Computational fluid dynamics modelling and simulation

Greenhouse physical model construction

Using relevant software for direct modelling, ignoring the impact of the top steel frame, according to the actual size of the greenhouse design and the relationship between the relevant parts, to create a 1:1 3D physical model.

Grid division

The grid was divided using related software, the wet curtain entrance was named inlet, the fan outlet was named outlet, and the top of the greenhouse, the surrounding enclosures, and the greenhouse ground were named as wall₁, wall₂, and wall₃, respectively. The roof of Venlo-type glass greenhouse is serrated, and its structure is irregular, so the Unstructured grid is chosen to divide the whole glass greenhouse discretely (Xu *et al.*, 2015). Considering the complexity of the flow around the wet curtain inlet and the fan outlet, grid encryption was applied to these areas. After meshing, tetrahedral and hexahedral meshes are generated, and a total of 367,960 nodes and 990,648 meshes are generated. As can be seen from Table 1, the mesh quality is good, and there is no negative volume, which meets the requirements of subsequent simulation.

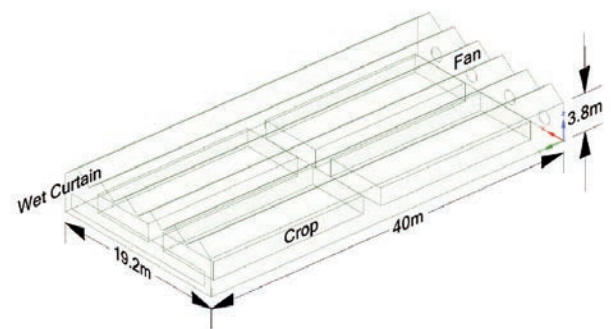

Figure 1. Schematic diagram of the greenhouse structure.

Table 1. Grid check report.

Check item (m^3)	Numerical value
Minimum mesh volume	1.715608×10^{-5}
Maximum mesh volume	1.255718×10^{-2}
Total mesh volume	$3.379200 \times 10^{+3}$

Boundary conditions and parameter settings

The CFD model adopts the turbulence model of standard k- ϵ , and the near wall area is treated by the standard wall function method. Due to airflow inside the greenhouse needing to be considered, the transient model is used for simulation (Xu *et al.*, 2015; Benni *et al.*, 2016). At the same time, the influence of solar radiation on the internal environment of the greenhouse should be considered, so we choose to use the energy Eq. and radiation model (*i.e.*, Do Model). The horizontal solar irradiance in the Xinyang area is 1030 W/m² in summer. In addition, humidity also has a certain impact on the indoor environment, requiring a component transport model. The crop area in the greenhouse is set as a porous media domain. The wet curtain acts as a pressure inlet, and the fan as a velocity outlet condition. The top of the greenhouse, the surrounding enclosures, and the ground are all set as wall boundary conditions (Chen, 2018). The parameters are set in Tables 2-5.

Solution setup

The solver has four control algorithms: SIMPLEC, SIMPLE, PISO, and Coupled (Yan, 2020). The SIMPLE algorithm is selected in this study, and related software is used for simulation (Huang and Zhao, 2013).

Grid independence test

Generally speaking, the density of the grid will change the simulation results to a great extent, but it is not the more the number

of grids, the better the simulation results. In fact, when the number of meshes reaches a certain level, continuing to increase the number of meshes has minimal effect on the simulation results and only increases the simulation time. Therefore, a grid independence check is required.

Three different mesh models were selected for testing: model A (1,441,904 meshes), model B (1,220,619 meshes), and model C (990,648 meshes) for simulation experiments. By selecting 6 positions in the greenhouse [T₁ (6.4 m, 8 m, 1 m); T₂ (6.4 m, 32 m, 1 m); T₃ (9.6 m, 10 m, 0.8 m); T₄ (9.6 m, 30 m, 0.8 m); T₅ (15 m, 20 m, 1.2 m); T₆ (15 m, 35 m, 1.2 m)] we obtained the simulated temperature values respectively and conducted the comparative analysis. The test results are shown in Table 6. The results show that the temperature values simulated by model A, model B, and model C have little difference, but the simulation time of model A and model B is longer, so model C can be selected to meet the simulation requirements.

Table 2. Crop porous media model parameter settings.

Parameter type	Numerical value
Crop canopy pressure drop coefficient (C ₀)	0.395
Crop internal loss factor (C ₁)	0.2
Crop porosity	0.7

Table 3. Material substance parameter settings.

Parameter type	Glass	PC board	Soil	Air	Crop
Density, kg/m ³	2200	1220	1900	1.225	700
Specific heat capacity, J/(kg·K)	753.62	1200	2200	1006.43	2310
Thermal conductivity, W/(m·K)	0.71	0.19	2	0.0242	0.17
Scattering coefficient	0	0.1	1	0	~
Absorption coefficient	0.1	0.12	0.5	0	0.26
Refractive index	1.52	1.5	1	1	2.77
Aerodynamic viscosity, kg/(m·s)	~	~	~	1.83×10 ⁻⁵	~

Table 4. Inlet and outlet boundary parameter settings.

Boundary types	Pressure-inlet	Velocity-outlet
The inlet relative total pressure, Pa	0	~
Wind velocity, m/s	~	-3
Standing temperature, K	299.3	304.38

Table 5. Top, surrounding enclosures, and ground boundary parameter settings.

Setting items	Top	Surrounding enclosures	Ground
Boundary types	Wall	Wall	Wall
Heat transfer forms	Convection	Convection	Mixed
Heat transfer coefficient, W/(m ² ·K)	3.5	6.7	0.5
Free flow temperature (K)	309.62	304.62	299.55
Internal radiation rate	0.79	0.86	0.90
Surface materials	PC sunshine plate	Float glass	Soil
Transparency type	Semi-transparent	Semi-transparent	Opaque
External radiation (K)	~	~	299.55
External radiation rate	~	~	1

Results and Discussion

Fluent software simulation

In this study, ANSYS software Fluent module was used to carry out numerical modelling and simulation of the experimental greenhouse. In this simulation, the maximum number of iterative calculations per unit time step is 10, and the number of solving time steps is 1035. The results are shown in Figure 2-4. As seen from Figure 2, the temperature increases gradually along the negative direction of the Y-axis, and the temperature near the wet curtain are about 299.29 K (26.14°C). The temperature near the fan is about 301.43 K (28.28°C). Overall, the temperature distribution inside the greenhouse is relatively uniform, which meets the growing environment of greenhouse crops. In the surrounding wall roof, the temperature is slightly higher to maintain at 304 K or so. It can be seen from Figure 3 that the wind speed at the entrance of the wet curtain and the outlet of the fan is higher, and the wind speed gradually decreases from the entrance and outlet to the inside of the greenhouse. As can be seen from Figure 4, the relative humidity in

Table 6. Temperature comparison under different models.

Location	Model	Temperature °C
T ₁	A	28.51
	B	28.56
	C	28.54
T ₂	A	26.30
	B	26.31
	C	26.32
T ₃	A	28.21
	B	28.18
	C	28.23
T ₄	A	26.40
	B	26.41
	C	26.46
T ₅	A	27.85
	B	28.00
	C	28.08
T ₆	A	26.30
	B	26.33
	C	26.31

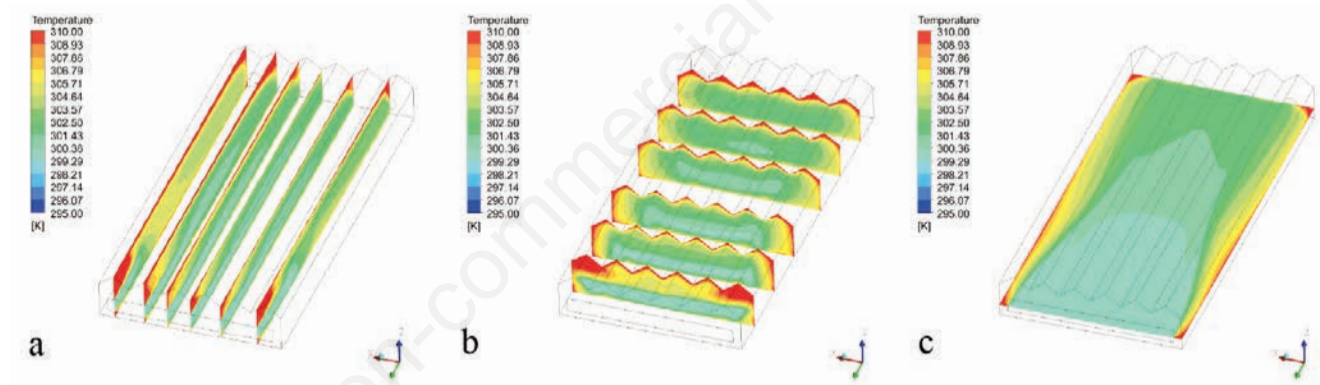

Figure 2. Simulation diagram of temperature field in different sections of the greenhouse. a) X-axis vertical sections; b) Y-axis vertical sections; c) Horizontal section 1.2 m above the ground.

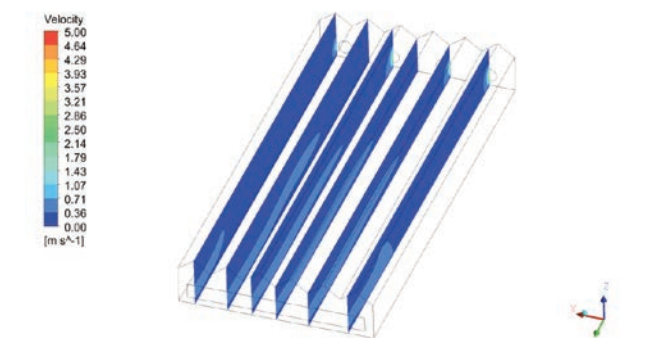

Figure 3. Simulation diagram of the velocity field in different sections of the greenhouse.

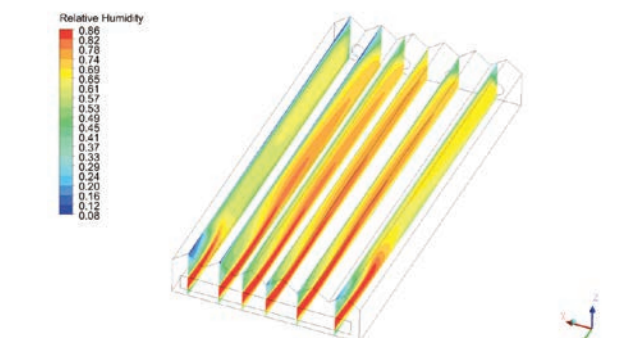

Figure 4. Simulation diagram of relative humidity field in different sections of the greenhouse.

the greenhouse is concentrated between 57-86% and gradually decreases from the entrance to the exit. The result of the simulation analysis accords with the actual situation.

Experimental analysis

In order to verify the simulation results, this experiment was carried out in a glass greenhouse in the Xinyang area, as shown in Figure 5. Indoor environmental sensors are used to monitor greenhouse data in real-time, and outdoor environmental monitors are used to monitor the outdoor environment.

Through the establishment of the real-time monitoring system of the greenhouse environment, the air temperature, light intensity, soil temperature, soil moisture, and other environmental indicators in the greenhouse can be monitored in real-time, and the internal and external of the greenhouse shading system, wet curtain pump, and exhaust motor can be automatically controlled by PLC and other programs, to achieve automatic control of greenhouse environment. As long as the temperature in the greenhouse is above 28°C, the cooling system will automatically start.

In order to test the difference between the actual environmental data and CFD simulation, and to test the performance of the greenhouse cooling system, the temperature and relative humidity of the sensor in the greenhouse at different times on July 13, 2021, were collected, and the simulated temperature and relative humidity of the sensor at different time positions were simulated by the established greenhouse CFD model. Part of the measured data at sensor A (9.6 m, 16 m, 1.2 m) was compared with simulated data, as shown in Figure 6. The comparison shows that the change changing trend of measured and simulated temperature measured relative humidity and simulated relative humidity are similar. The values are consistent, which proves that the established greenhouse CFD model is correct, and it can be seen that the greenhouse cooling system is generally effective.

Optimised design

The above experiments prove that the designed cooling system of the Internet of Things greenhouse is effective. However, due to the design, considering the layout of the landscape around the greenhouse, greenhouse building land shortage, and other problems, resulting in the greenhouse cooling system cooling effect is not good. Therefore, optimising the design to improve its cooling effect is necessary. This paper takes Xinyang Area IOT glass greenhouse as the design object.

Considering Xinyang is located in the northern hemisphere,

the prevailing southeast wind in summer in Xinyang, and the basic greenhouse structure, the design of the east-west wet curtain-fan cooling system. First, install the wet curtain on the east gable of the greenhouse, 0.5 m above the ground; the fan is installed in the west gable of the greenhouse, 0.4 m above the ground.

In order to meet the air volume required for cooling, the greenhouse is equipped with six axial flow fans (380 V, 0.55 KW) with a diameter of 1 m and an air volume of 30,000 m³/h. The fan position coordinates are (0 m, 3 m, 0.9 m), (0 m, 9.8 m, 0.9 m), (0 m, 16.6 m, 0.9 m), (0 m, 23.4 m, 0.9 m), (0 m, 30.2 m, 0.9 m), (0 m, 37 m, 0.9 m). If the length of the wet curtain is not enough, it is easy to form a cooling corner in the greenhouse. Therefore, a wet curtain with specifications of 39.6×1.5×0.1 m was selected for the design. The optimised design is shown in Figure 7.

Optimisation simulation analysis

It can be seen from Figure 8 that the temperature increases gradually along the negative direction of the X-axis, but the temperature variation gradient is small, and the distribution is uniform,



Figure 5. Enmental sensor in the greenhouse.

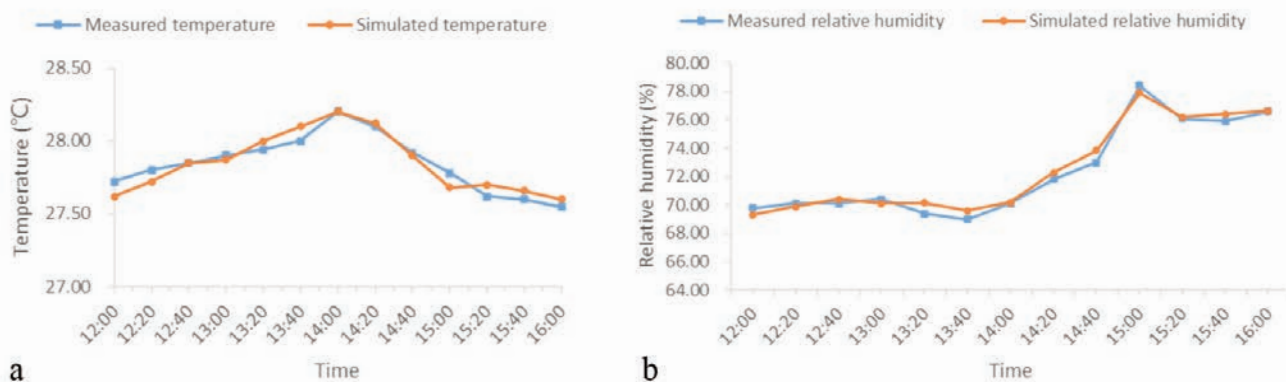

Figure 6. Comparison of measured and simulated data at sensor A of the greenhouse at different times. a) Temperature; b) relative humidity.

all at about 300.36 K (*i.e.*, 27.21°C), which is more conducive to the growth of crops. There is a specific temperature gradient in the greenhouse. The temperature near the ground is relatively flat, while the temperature gradient at the upper part of the greenhouse is more obvious, and the temperature is higher. It can be seen from Figure 9 that the wind speed at the entrance of the wet curtain and the outlet of the fan is higher, and the velocity gradient is larger. Wind speed gradually decreases from the entrance and exit of the greenhouse to the inside of the greenhouse, while the wind speed distribution in the greenhouse is relatively uniform, with little change, in line with the requirements of crop growth. It can be seen from Figure 10 that the relative humidity in the greenhouse is between 61% and 85%, which is more conducive to crop growth.

As can be seen from Table 7, according to the greenhouse ventilation volume and summer wind direction in the Xinyang area, the east-west wet curtain-fan cooling system with multiple low-power fans has a more significant cooling effect, lower energy consumption, and higher economic efficiency than the original south-north wet curtain-fan cooling system.

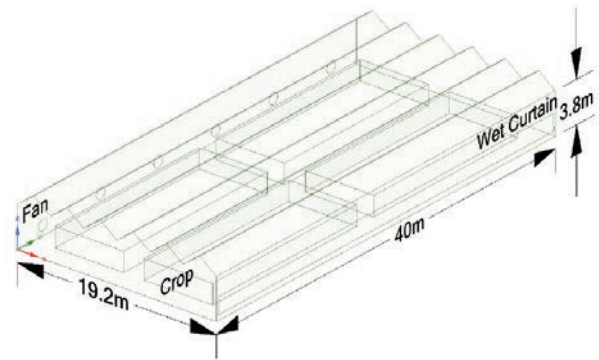

Figure 7. Design diagram of the optimised cooling system.

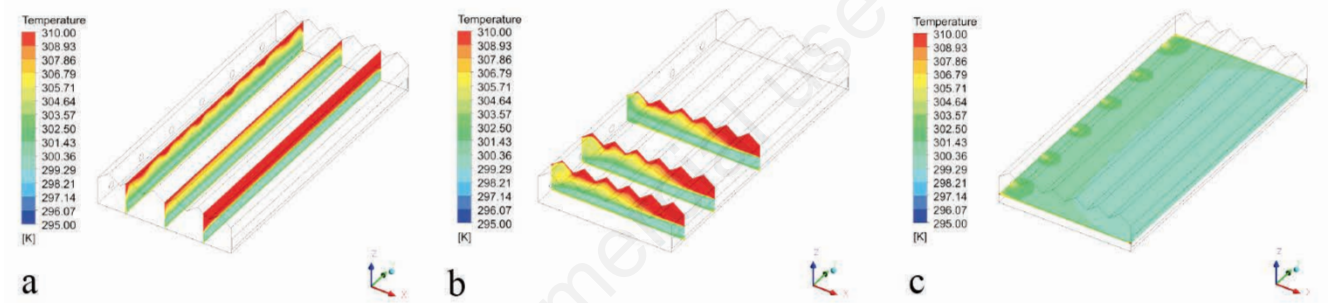

Figure 8. Simulation diagram of temperature field at different sections. a) X-axis vertical sections; b) Y-axis vertical sections; c) horizontal section 1.2 m above the ground.

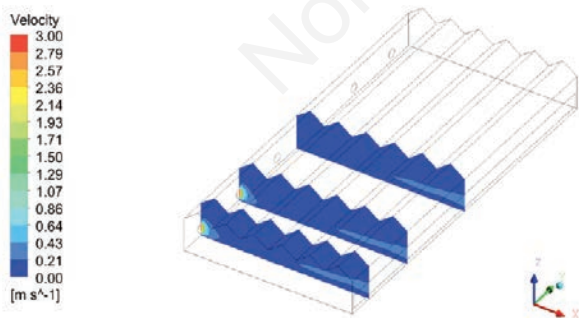

Figure 9. Simulation diagram of the velocity field at different sections.

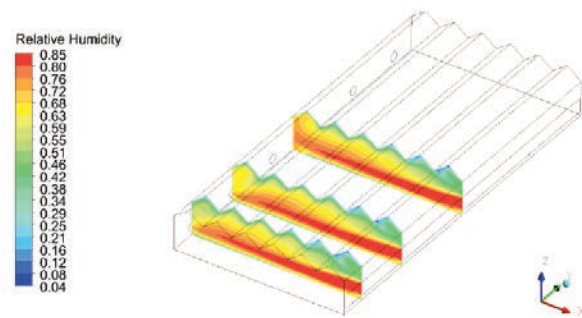

Figure 10. Simulation diagram of relative humidity field at different sections.

Table 7. Comparison of cooling effects of different systems.

Designing scheme	Total fan power, KW	Cooling effect
South-north wet curtain-fan cooling system	4.4	The temperature of the fan and near the round surface is higher
East-west wet curtain-fan cooling system	3.3	The temperature distribution is uniform in the greenhouse

Conclusions

Based on the analysis of the greenhouse heat balance theory, the calculation model of total cooling load and the model of the greenhouse thermal environment is established in this paper. Using the calculation model of the total cooling load of the greenhouse, the ventilation volume required by the cooling system of the wet curtain fan can be calculated, and then the appropriate fan model can be selected, which can effectively reduce the energy consumption of the greenhouse cooling system. Furthermore, the CFD model of the greenhouse was established by considering the thermal environment model of the greenhouse, and the experiment proved that the model is accurate, which can clearly show the changes of temperature field in the greenhouse, and can be used in the study of greenhouse cooling system. At the same time, the model can also be used to predict the change in the greenhouse environment under the wet curtain-fan cooling system so that the growers can adjust the indoor environment in time to avoid crop damage, resulting in production reduction. The two designs in this paper can provide some reference for designing the same type of greenhouse cooling system.

References

- Benni S., Tassinari P., Bonora F., Barbaresi A., Torreggiani D. 2016. Efficacy of greenhouse natural ventilation: environmental monitoring and CFD simulations of a study case. *Energy Build.* 125:276-86.
- Boulard T., Roy J.C., Fatnassi H., Kichah A., Lee I.B. 2010. Computer fluid dynamics prediction of climate and fungal spore transfer in a rose greenhouse. *Comput. Electron. Agric.* 74:280-92.
- Boulard T., Roy J.C., Pouillard J.B., Fatnassi H., Grisey A. 2017. Modelling of micrometeorology, canopy transpiration and photosynthesis in a closed greenhouse using computational fluid dynamics. *Biosyst. Eng.* 158:110-33.
- Bournet P.E., Boulard T. 2010. Effect of ventilator configuration on the distributed climate of greenhouses: a review of experimental and CFD studies. *Comput. Electron. Agric.* 74:195-217.
- Chen Y.W. 2018. Study on optimization of CFD simulation of energy-saving cooling by South China-styled multi-span greenhouse. South China Agricultural University.
- Cheng X.H., Mao H.P., Ni J. 2011. Numerical prediction and CFD modeling of relative humidity and temperature for greenhouse-crops system. *Trans. Chin. Soc. Agric. Mach.* 42:173-9.
- Dong X.Y. 2019. Characteristic analysis and CFD model establishment of different external thermal insulation cover materials in solar greenhouse. Shenyang Agricultural University.
- Franco A., Valera D.L., Pena A., Perez A.M. 2011. Aerodynamic analysis and CFD simulation of several cellulose evaporative cooling pads used in Mediterranean greenhouses. *Comput. Electron. Agric.* 76:218-30.
- Ghoulem M., Moueddeb K.E., Nehdi E., Boukhanouf R., Calautit J.K. 2019. Greenhouse design and cooling technologies for sustainable food cultivation in hot climates: review of current practice and future status. *Biosyst. Eng.* 183:121-50.
- Ghoulem M., Moueddeb K. E., Nehdi E., Zhong F. L., Calautit J. 2020. Analysis of passive downdraught evaporative cooling windcatcher for greenhouses in hot climatic conditions: parametric study and impact of neighbouring structures. *Biosyst. Eng.* 197:105-21.
- Huang Q.F., Zhao Y. 2013. A simulation on temperature field and dynamic characters of a forced ventilated greenhouse in summer. *J. Agric. Mech. Res.* 35:30-3.
- Hu J. 2020. Application of CFD numerical simulation technology in greenhouse environmental factor regulation. *Agr. Eng.* 10:43-8.
- Jia H.M., Han J.C., Zhang S., Sun K.J., Li Y. 2019. Numerical analysis simulation and optimization of the environment in glass greenhouse based on CFD. *Appl. Sci. Technol.* 46:28-33.
- Li L.L., Wang X. Z., Hong Y.J., Lu Q., Chen J. 2019. Analysis of canopy radiation and temperature field in greenhouse under different shading conditions based on CFD. *J. Agric. Mech. Res.* 41:192-7.
- Liu J., Cui T., Wang C.D., Li X., Ma C.W., Zhang T.Z. 2018. Cooling technology of multi-span greenhouse in summer. *J. Agric. Mech. Res.* 40:262-8.
- Liu Y.J., Xu J.T., Pang S.R., Sun Z.P., Li T.L. 2019. Design of positive-pressure wet curtain fan system for solar greenhouse and its cooling effects. *J. China Agric. Univ.* 24:130-9.
- Ma L. 2020. Research on CFD temperature simulation model of solar greenhouse based on tomato group effect. Shenyang Agricultural University.
- Santolini S., Pulvirenti B., Guidorzi P., Bovo M., Torreggiani D., Tassinari P. 2022. Analysis of the effects of shading screens on the microclimate of greenhouses and glass facade buildings. *Build. Environ.* 211:108691.
- Shougang R., Wei Y., Haoyun W., Wei X., Huanliang X., Yingjun X. 2015. Prediction model on temporal and spatial variation of air temperature in greenhouse and ventilation control measures based on CFD. *Trans. Chin. Soc. Agric. Eng.* 31:207-14. [Article in Chinese].
- Weituo S., Bo Z., Fan X., Chao S., Lu C., Wenzhong, G. 2019. Performance of positive pressure fan-pad cooling system and cooling load model for Chinese solar greenhouse. *Trans. Chin. Soc. Agric. Eng.* 35:214-24. [Article in Chinese].
- Wu C., Cheng R., Fang H., Yang Q., Zhang C. 2021. Simulation and optimization of air tube ventilation in plant factory based on CFD. *J. China Agric. Univ.* 26:78-87.
- Xu D. 2017. Application of dutch large glass greenhouse technology in China. *Agric. Eng. Technol.* 37:28-30.
- Xu F., Cai Y., Chen J., Zhang L. 2015. Temperature/flow field simulation and parameter optimal design for greenhouses with fan-pad evaporative cooling system. *Trans. Chin. Soc. Agric. Eng.* 31:201-8. [Article in Chinese].
- Xu J., Li Y., Wang R.Z., Liu W., Zhou P. 2015. Experimental performance of evaporative cooling pad systems in greenhouses in humid subtropical climates. *Appl. Energy.* 138:291-301.
- Yan L.L. 2020. Effects of different natural ventilation methods on Solar Greenhouse environment and tomato growth. Northwest A&F University.
- Zhao C., Tan H.W., Shi H.F. 2011. Cooling performance of evaporative cooling pad-fan unit in greenhouse in hot and humid environment. *Heating Ventilating Air Conditioning* 41:108-12.
- Zhou Z.C., Zhao J., Li X.G., Wang W.S. Dong W., Lan L.B. 2018. Experimental study of summer cooling in semi-closed greenhouse. *Agr. Eng.* 8:46-9.